

tousek Rollco® LWS 100, 110, 120

Cantilever Systems for Sliding Gates

strong & silent



Sliding gate operators



Cantilever sl. gate sys.



Swing gate operators



Garage door operators



Barrier operators



El. gate control



Impulse emitters



Safety devices



Miscellaneous



tousek[®]
AUTOMATIC GATE OPERATORS

tousek Rollco® LWS 100, 110, 120

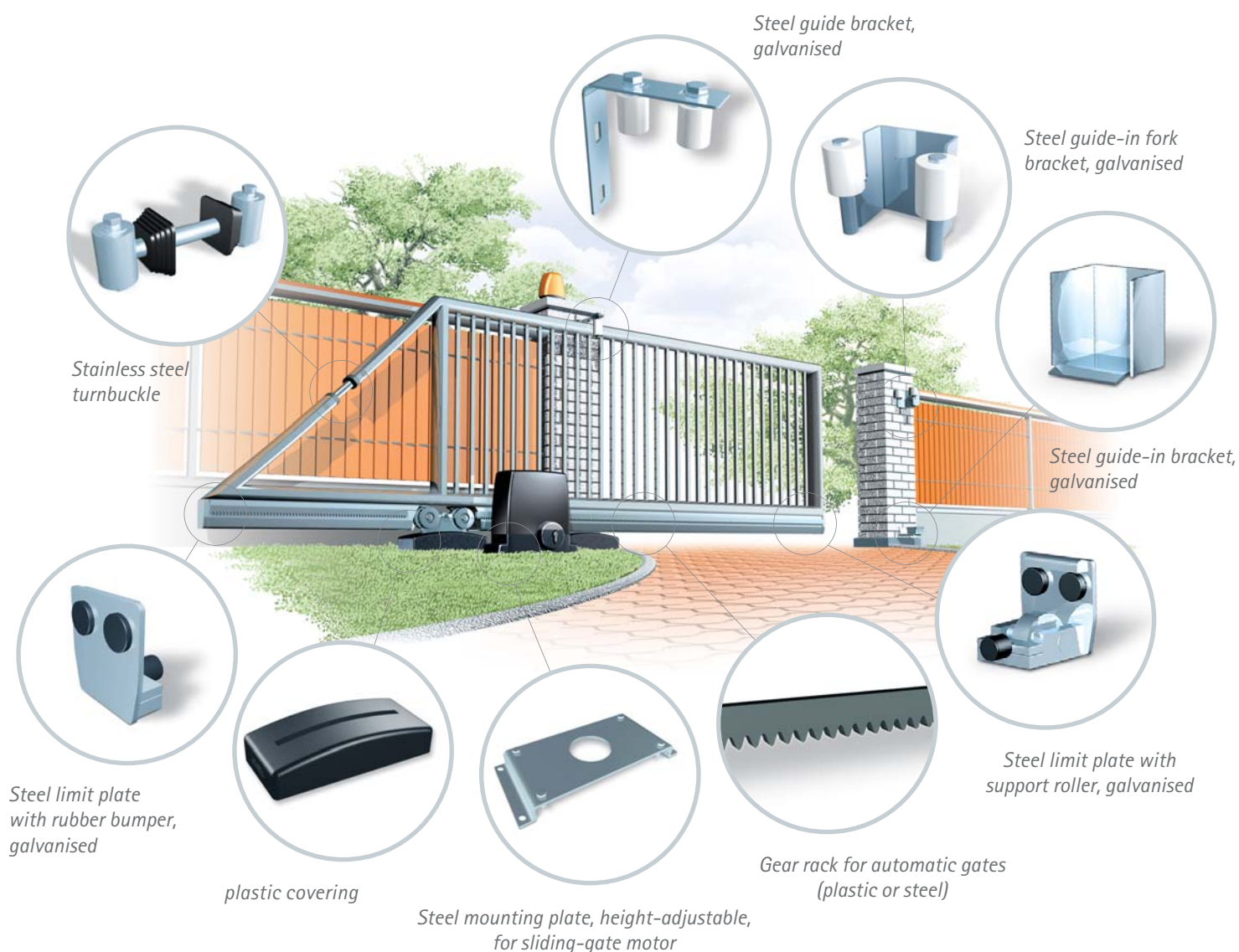

Rails of galvanised steel for all cantilevered sliding gates with a passage width of up to seven metres

With the Rollco® LWS 100, 110, 120 cantilever system, tousek has realised a new concept. The rail, of high-quality, hot-dip galvanised steel is suitable for use outdoors without any further surface treatment.

Modern cantilevered sliding-gate constructions are advantageous in many ways. The most important one: imperviousness to ice and snow, the gate hovers away from all ground unevenness.

The solid roller unit, with its large, ball-bearing supported steel rollers, ensures optimal guidance and guarantees the greatest quiet in operation, even at maximum load, and reliability for many, many years.

The adjuster screw prevents the tilt-effect during endurance reactions. The maintenance-free ball bearings, impervious to dust, are another characteristic of highest tousek quality.



Roller unit LWS 120

Solid construction, galvanised, with stainless steel sub-plating, ball-bearing supported steel rollers for quiet running

- strong and silent

- maximum quiet when running
- optimal resistance to corrosion
- time-saving installation
- high carrying power

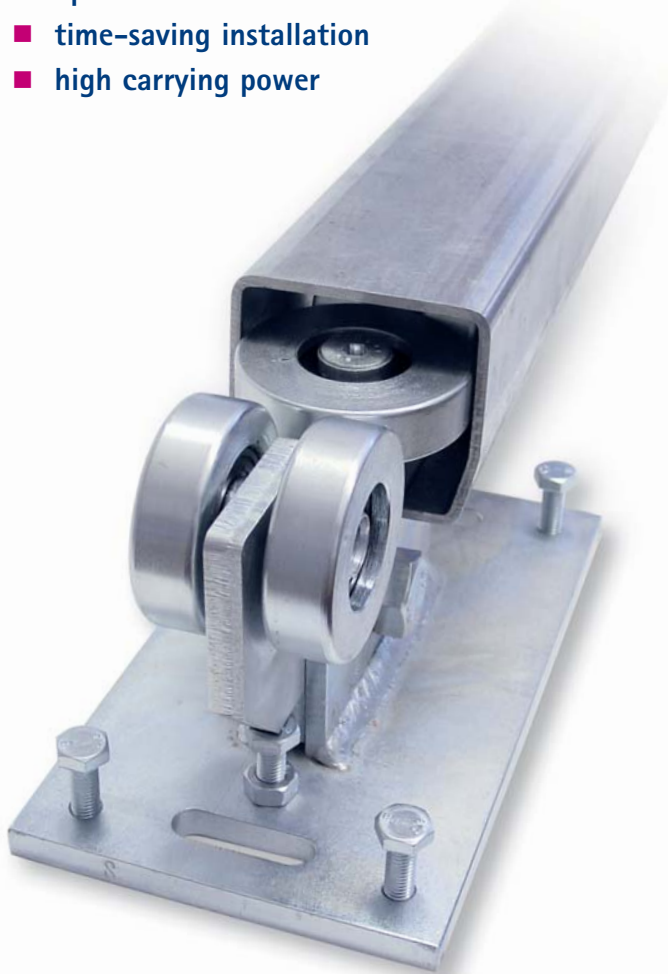

Quiet

In combination with the solid roller unit and the large, ball-bearing supported steel rollers, the steel rails guarantee maximum quiet when running.



Compatible

The tousek Rollco® LWS 100, 110, 120 cantilever systems for sliding gates have been optimally designed to be compatible with the tousek Pull sliding gate series. Naturally, both systems can also be operated manually.

Rational

Installation is rational and time-saving, thanks to the thoroughly worked out system construction and the comprehensive accessories assortment.

Strong

Solid and stable construction permits smooth movement of even the largest and heaviest gates.

Durable

Using hot-dip galvanised steel makes the cantilever sliding gate system impervious to damp, snow and ice.

Rollenbock Rollco® LWS 110



tousek
AUTOMATIC GATE OPERATORS

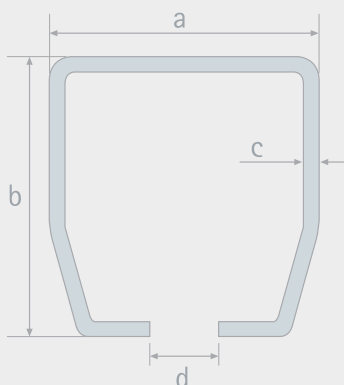

in mm	LWS 100	LWS 110	LWS 120
a	75	92	98
b	69	84	112
c	3	4	6
d	30	30	30

Designation	LWS 100	LWS 110	LWS 120
material	hot-dip galvanised steel band QSTE 420 TM		
rail measurements	75/69/3mm	92/84/4 mm	98/112/6 mm
surface	hot-dip galvanised steel band		
carrying power	20 kg/lfm	25 kg/lfm	50 kg/lfm
gate frequency	20 cyc./day	20 cyc./day	100 cyc./day
weight	5,5 kg/lfm	ca. 9 kg/lfm	ca. 16 kg/lfm
max. passage width	4000 mm	4000 mm	7000 mm
max. gate length	6000 mm	6000 mm	10185 mm
distance from ground	60 mm	75 mm	90 mm

Note: Please be aware that the gate-security devices shown in this brochure are examples and are not to be considered as guidelines with regard to applicable standards. The standards in effect in each country must be complied without fail during start-up and/or installation.

See the technical specification sheets for further details.
We reserve the right to alter measurements.



Eduard Tousek

tousek PRODUCTS

- Sliding-gate operators ▲
- Swing-gate operators ▲
- Garage-door operators ▲
- Folding-gate operators ▲
- Barriers ▲
- Parking systems ▲
- Window operators ▲
- Domelight operators ▲
- Door operators ▲
- Electronic controls ▲
- Radio remote controls ▲
- Key switches ▲
- Access control ▲
- Security devices ▲
- Accessories ▲

For many years now,

we have been working on developing gate operators and their accessories at the forefront in the international field. Expertly trained employees and comprehensive service are two of the factors in satisfying customers' wishes.



tousek - the original

The Original tousek Quality certificate is your absolute guarantee of the highest quality when you purchase a tousek operator.



Reliable and secure

Tousek's leading technical development, including the Rolling Code Radio System, for instance, which generates a new radio code every time the remote control is activated, thus preventing the radio signal from being scanned by unauthorised persons, is your guarantee of greater security, in demand today as part of seamlessly protecting property. The quality of tousek products is guaranteed by the most stringent tolerances in manufacture and constant monitoring.

Compatibility

Tousek places great emphasis on keeping all elements of the gate operator, accessory and security programmes compatible as the assortment of products grows.



www.tousek.com

Your tousek partners will be happy to advise you personally.

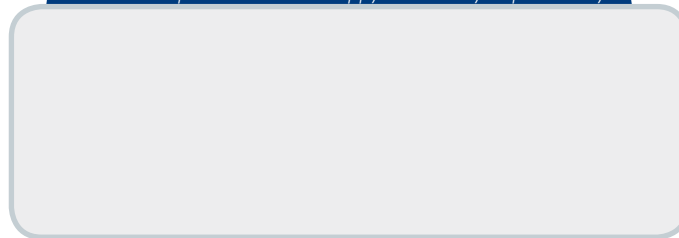

tousek swing gate operators
rational and strong



tousek barrier systems
attractive and robust



tousek sliding-gate operators
compact and safe



tousek impulse emitter
programmes
compatible and secure

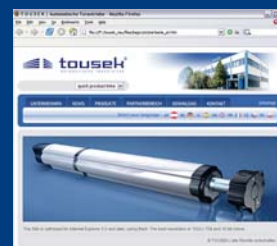

www.tousek.com

Visit our website for more important information all about automatic operators.

tousek Ges.m.b.H.
A-1230 Wien, Zetschegasse 1
Tel: +43/ 1/ 667 36 01
Fax: +43/ 1/ 667 89 23
Email: info@tousek.at

tousek GmbH
D-83395 Freilassing
Traunsteiner Straße 12
Tel: +49/ 8654/ 77 66 - 0
Fax: +49/ 8654/ 57 196
Email: info@tousek.de

tousek Sp. z o.o.
PL-43-190 Mikołów (k/Katowice)
Wyzwolenia 27
Tel: +48/ 32/ 738 53 65
Fax: +48/ 32/ 738 53 66
Email: info@tousek.pl

tousek s.r.o.
CZ-130 00 Praha 3, Jagellonská 9
Tel: +420/ 222 090 980
Fax: +420/ 222 090 989
Email: info@tousek.cz